

Solution
Partner

SIEMENS

PLM

BOĞAZIÇI
YAZILIM



NX 12 CAM Yenilikleri

www.bogaziciyazilim.com

Smarter decisions, better products.

-NX 12 ile birden çok parçayı çoklu pencere özelliği ile görüntüleyebilirsiniz.

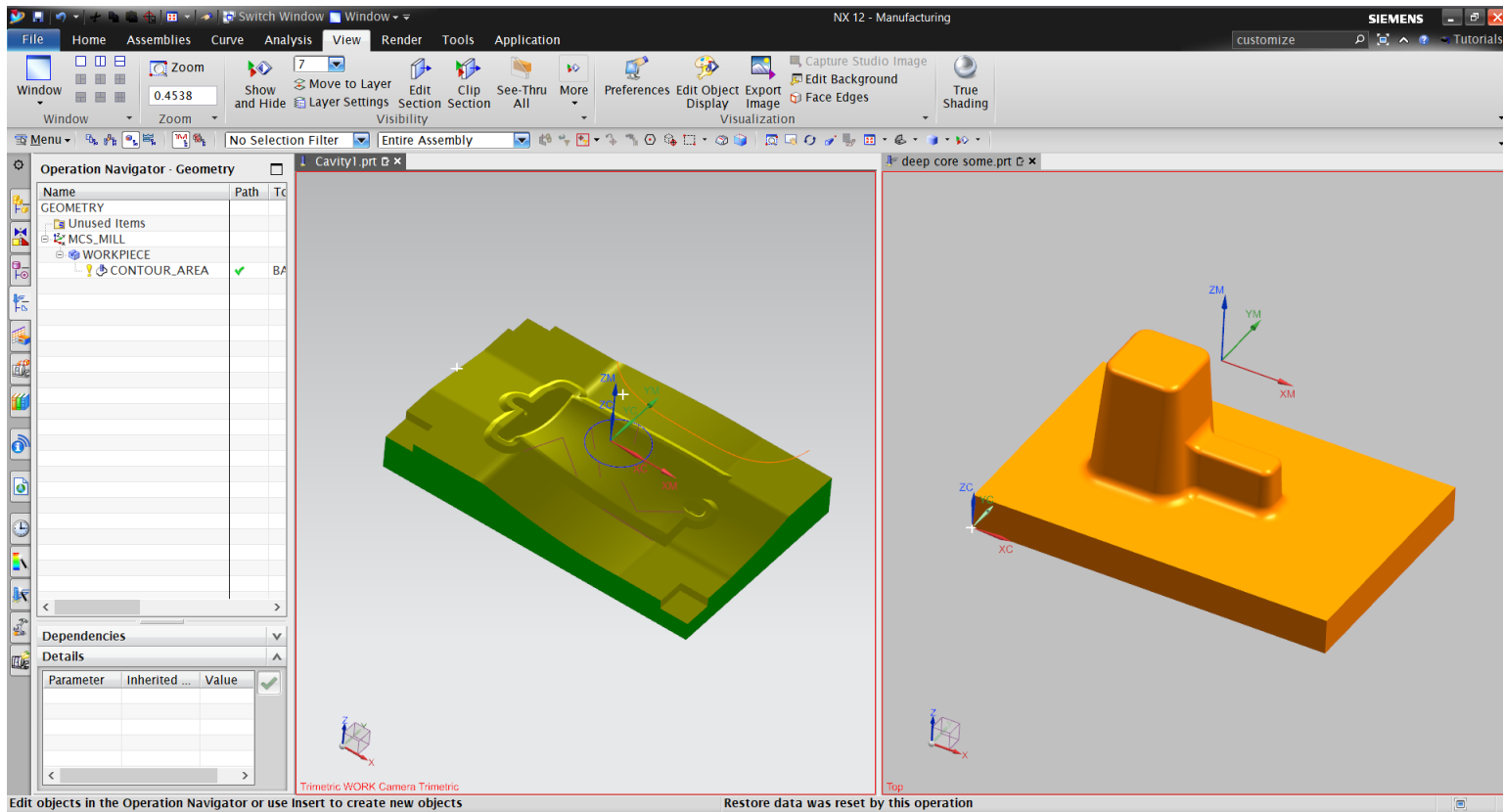

Dialog kutularını explorer ağacı formatında görüntüleme

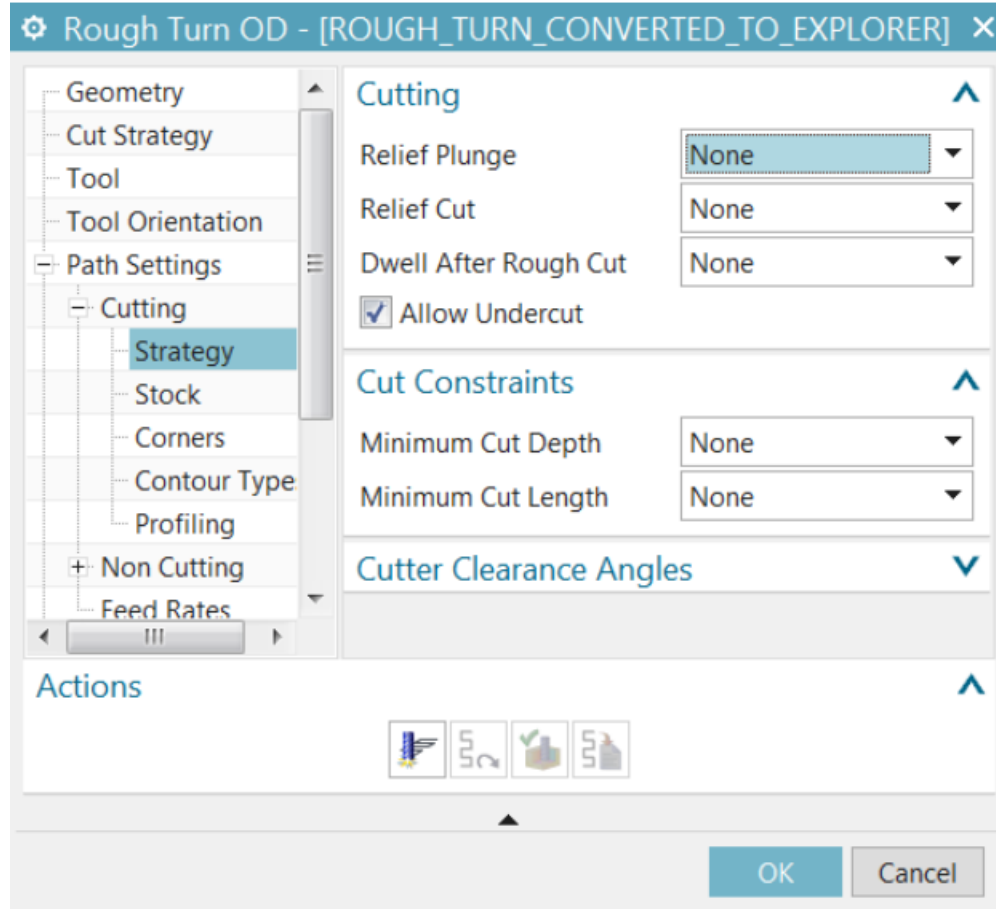

NX 12.0.1 Öncesi

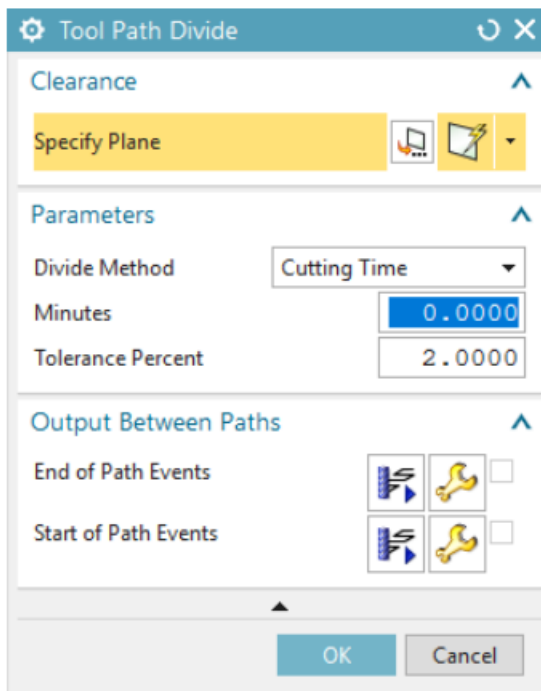

NX 12.0.1

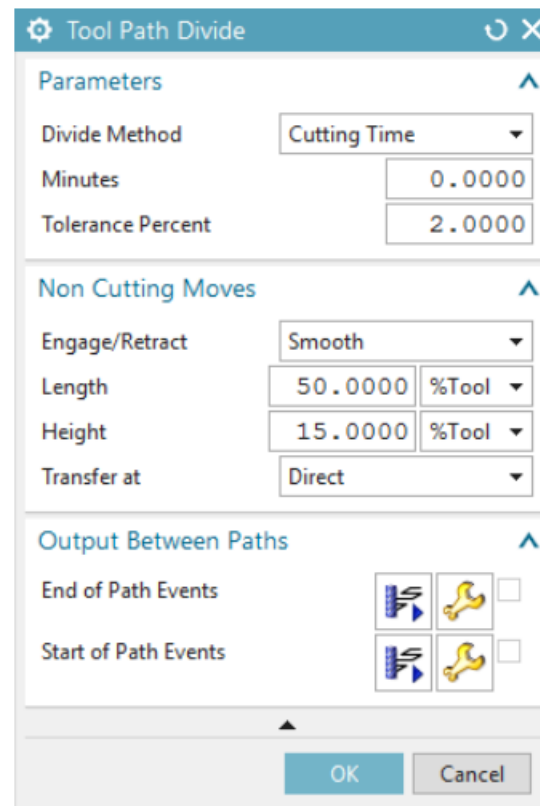

Animasyon Özelliği

-Takım hareketini Verify kısmına girmeden görebilirsiniz.

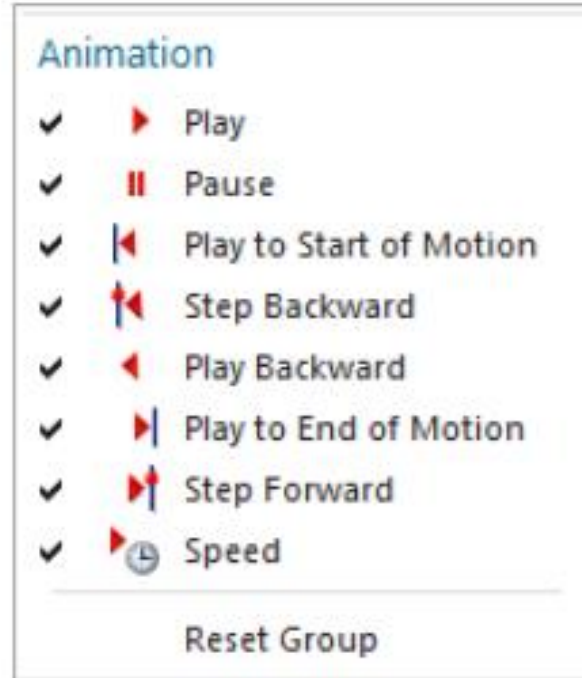

-Engage retract ve boştaki hareketlerde ayrı ayrı yumuşatma yapabiliyorsunuz.

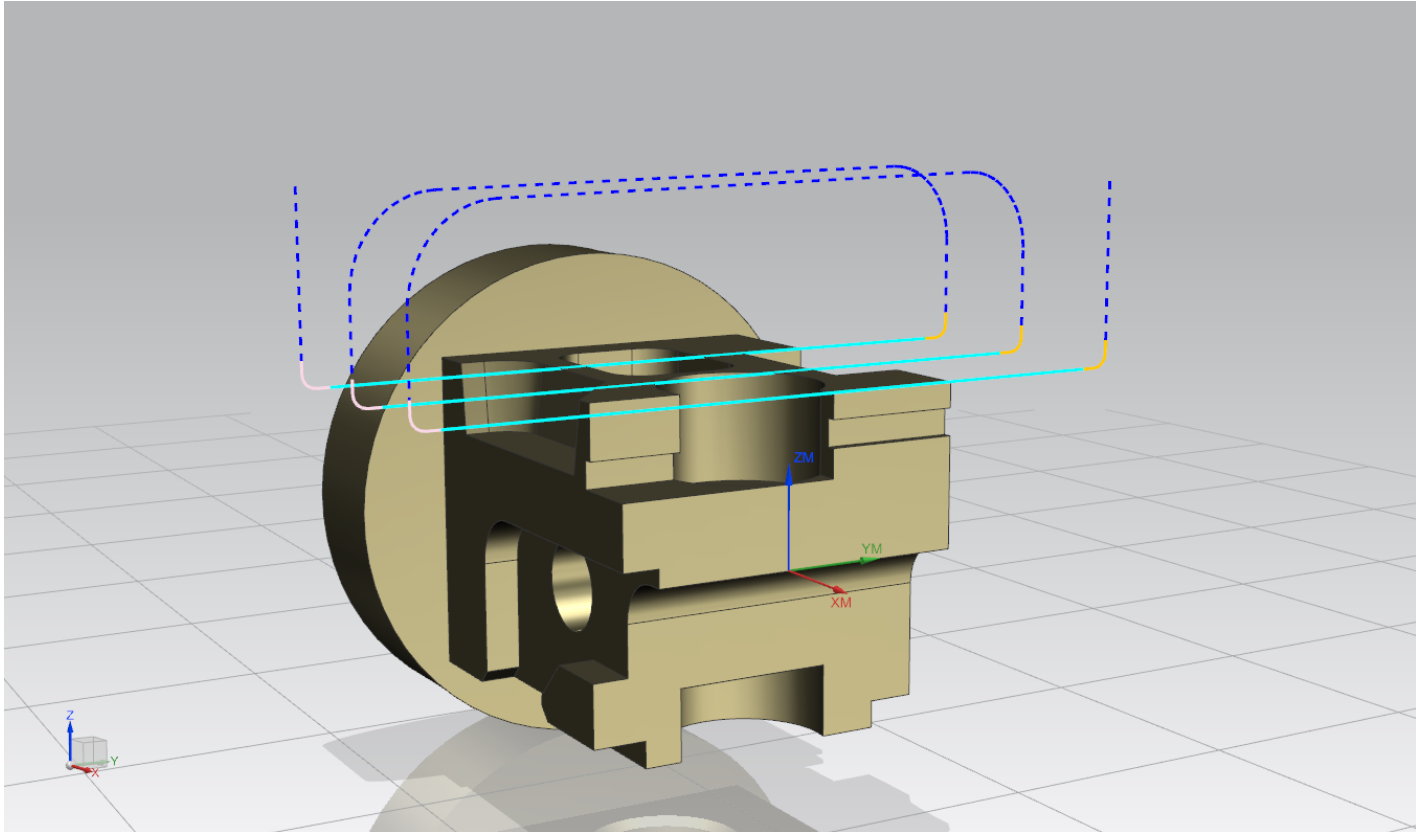

Son duvar pasosunu yumuşatmama seçeneği

-NX 12 ile smooth corners seçeneğinde son pasoyu yumuşatmayarak köşe radyüslerini tam çıkarma seçeneği gelmiştir.

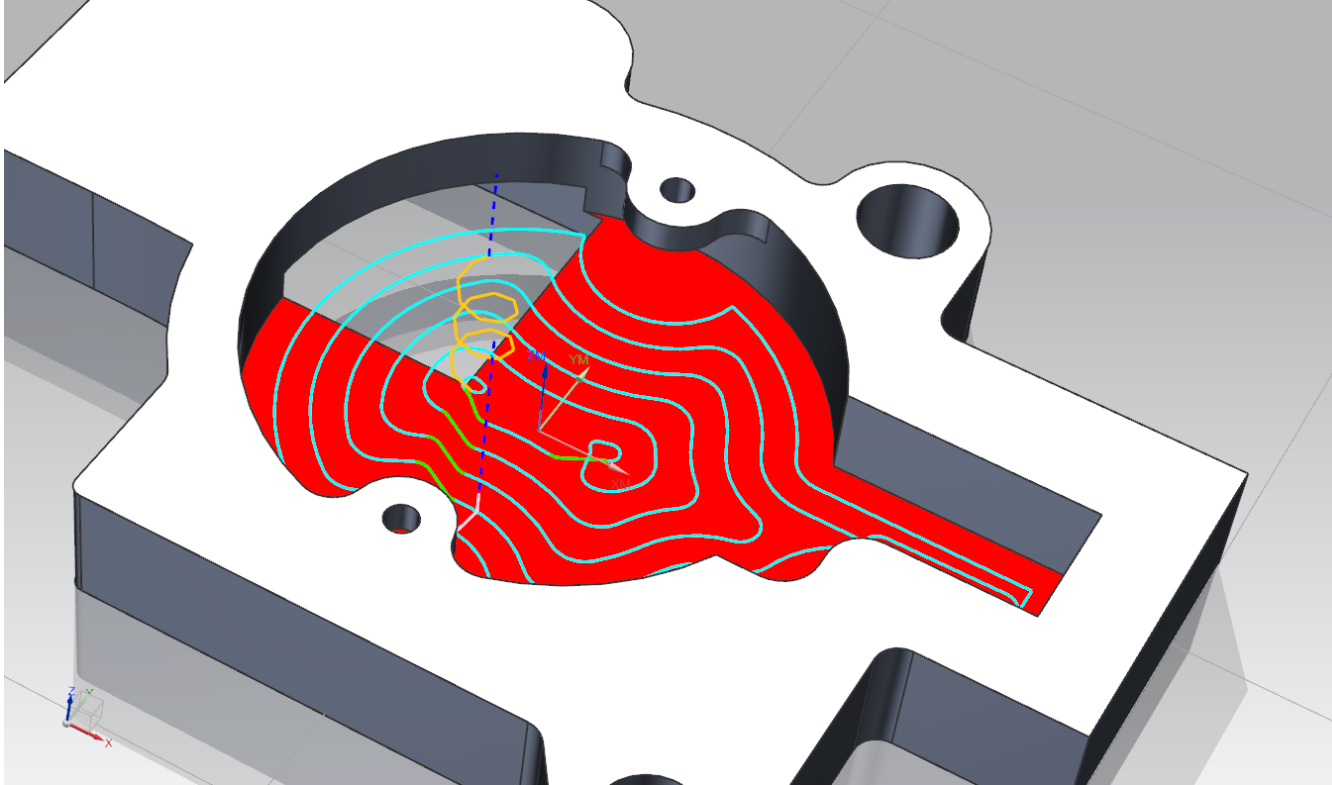

- NX12 ile takımın helisel olarak giremediği kısımlara plunge olarak girme seçeneği opsiyonel hale gelmiştir.

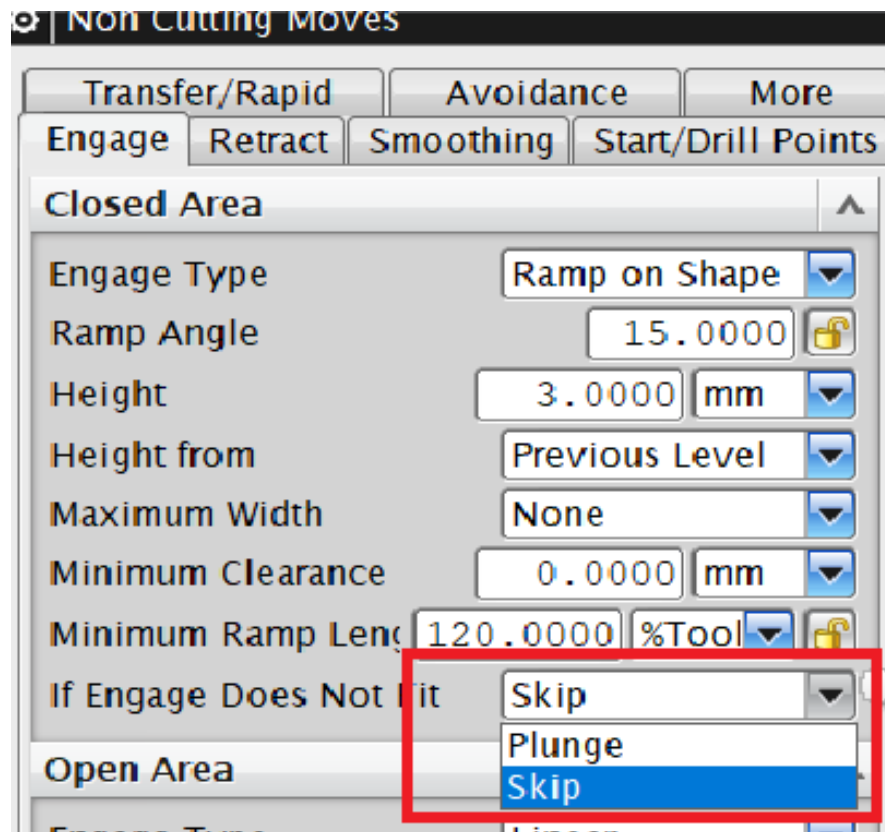

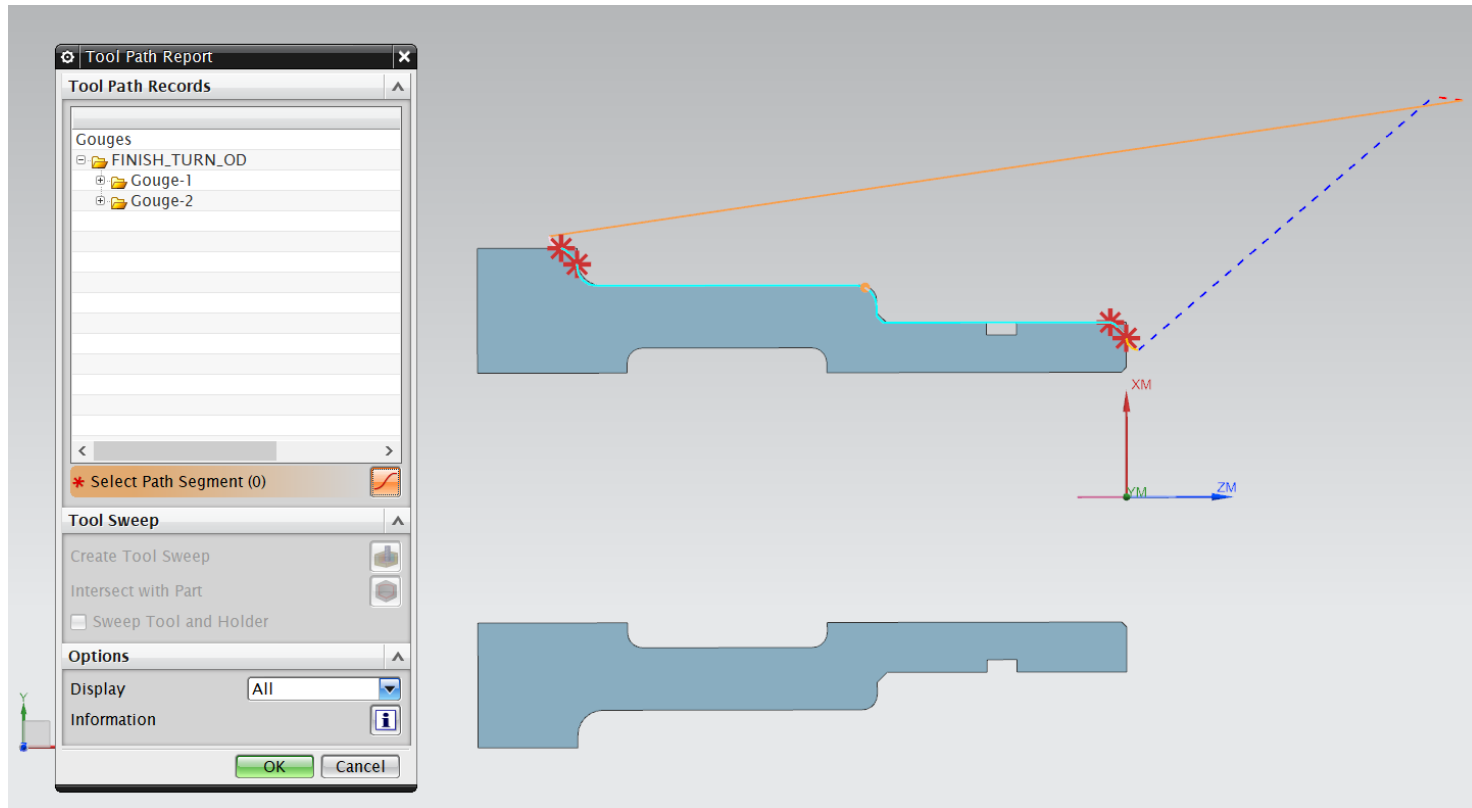

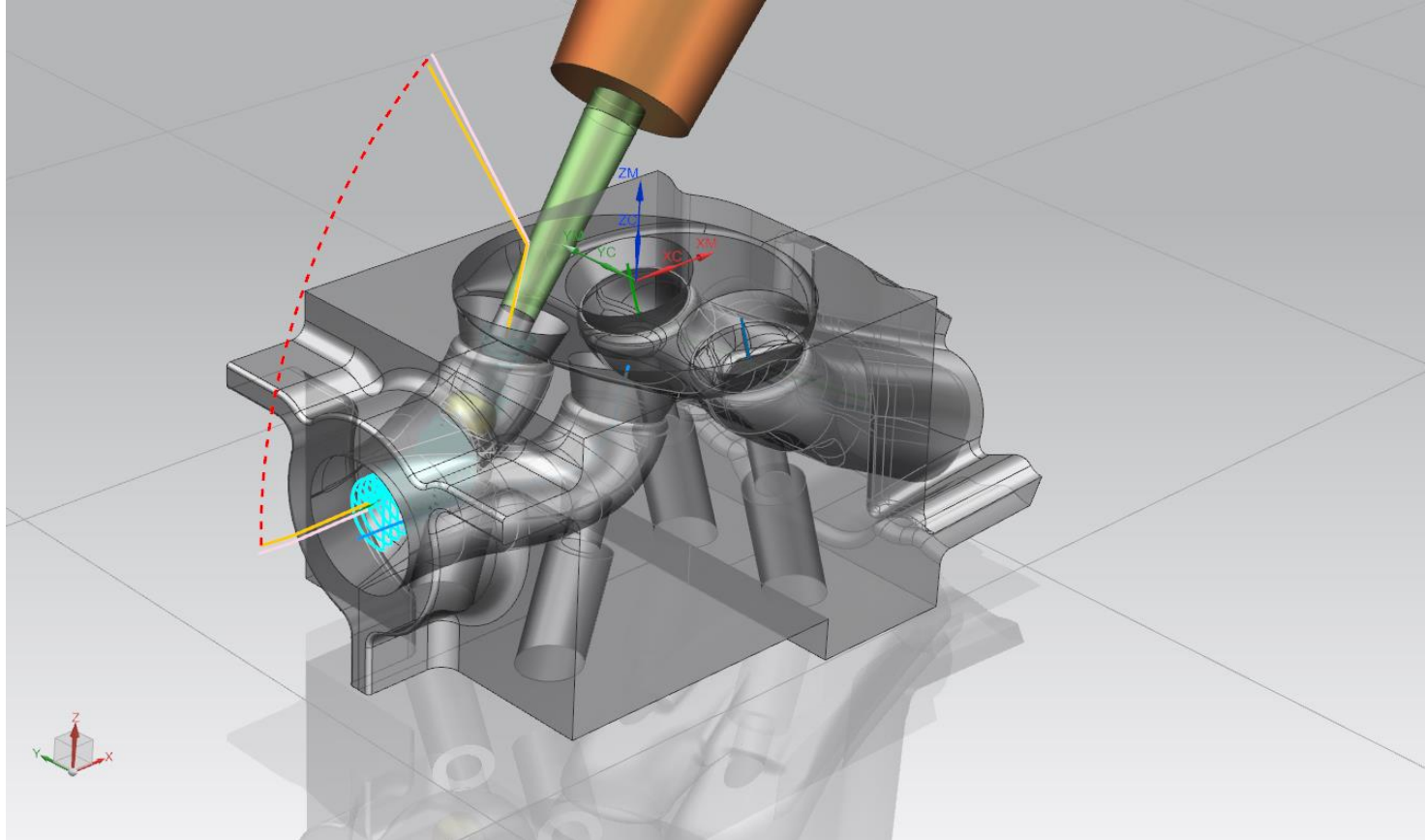

NX 12 ile aynalanmış operasyonları editleyebilirsiniz.

